

EB1000

electrabrake

electromagnetic sheet metal folding machines

MATERIAL (yield/ult stress)	THICKNESS (mm)	LIP WIDTH minimum (mm)	BEND RADIUS Typical (mm)
Mild Steel (250/320 MPa)	1.6	30*	3.5
	1.2	15	2.2
	1.0	10	1.5
Aluminium Grade 5005 H34 (140/160 MPa)	1.6	30*	1.8
	1.2	15	1.2
	1.0	10	1.0
Stainless Steel Grades 304, 316 (210/600MPa)	1.0	30*	3.5
	0.9	15	3.0
	0.8	10	1.8

* With Standard bending beam extension fitted. For most non-ferrous metals (copper, brass, zinc) refer to Aluminium above.

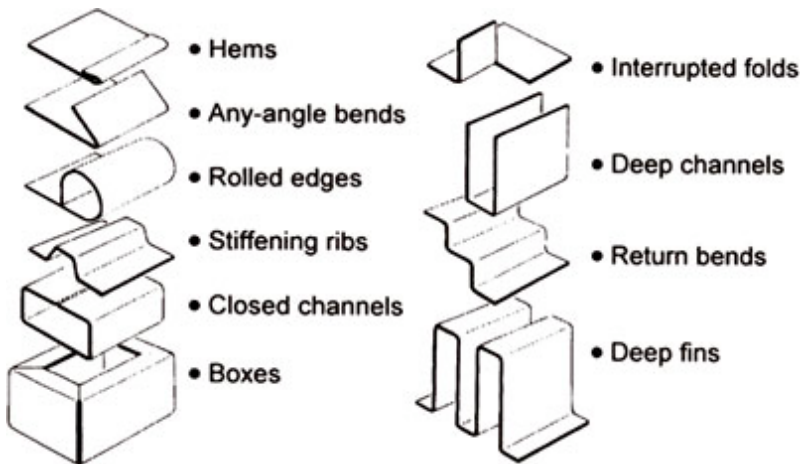

Special tooling can be quickly improvised from pieces of steel to help fold-up difficult shapes.

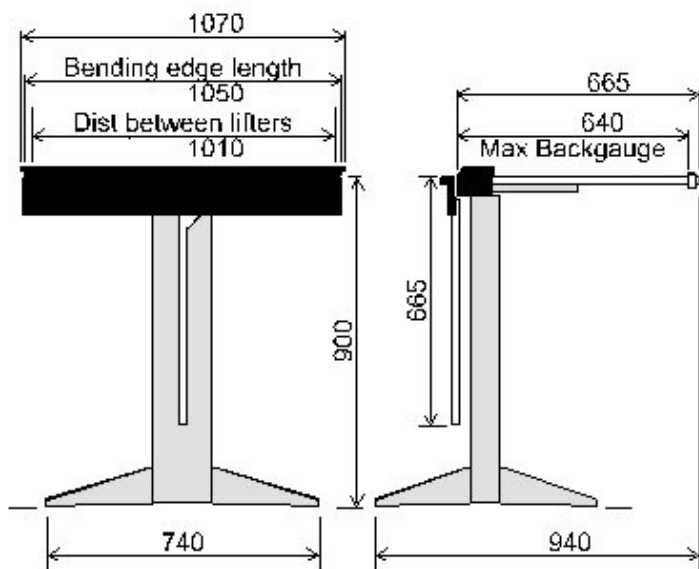

FRONT & SIDE ELEVATIONS

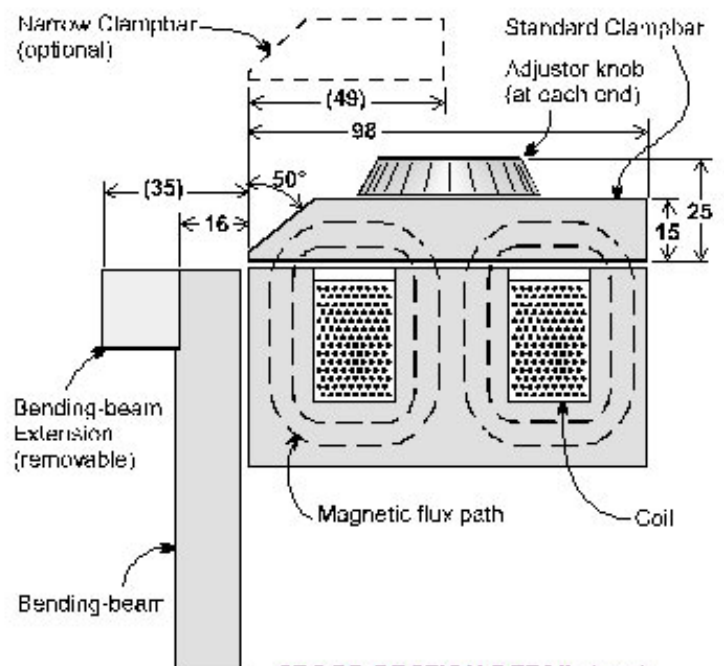

CROSS-SECTION DETAIL (mm)